

# Redundancy module, with protective coating - QUINT-ORING/24DC/2X20/1X40



2320186

<https://www.phoenixcontact.com/us/products/2320186>

Please be informed that the data shown in this PDF document is generated from our Online Catalog. Please find the complete data in the user documentation. Our General Terms of Use for Downloads are valid.



Active QUINT redundancy module for DIN rail mounting with ACB (Auto Current Balancing) Technology and monitoring functions, input: 24 V DC/2x 20 A, output: 24 V DC/1 x 40 A, including mounted UTA 107/30 universal DIN rail adapter

## Product Description

The Auto Current Balancing ACB technology of the QUINT ORING modules doubles the service life of redundantly operated power supplies by evenly utilizing the power supply units. The load current is automatically distributed symmetrically.

## Your advantages

- Service life of the redundant solution is doubled, thanks to uniform distribution of the load
- Save energy
- Permanent monitoring of redundancy
- Consistent redundancy up to the load

# Redundancy module, with protective coating - QUINT-ORING/24DC/2X20/1X40



2320186

<https://www.phoenixcontact.com/us/products/2320186>

## Commercial Data

Item number	2320186
Packing unit	1 pc
Minimum order quantity	1 pc
Sales Key	C15
Product Key	CMRQ43
Catalog Page	Page 303 (C-4-2019)
GTIN	4046356524919
Weight per Piece (including packing)	753 g
Weight per Piece (excluding packing)	600 g
Customs tariff number	85049090
Country of origin	CN

# Redundancy module, with protective coating - QUINT-ORING/24DC/2X20/1X40



2320186

<https://www.phoenixcontact.com/us/products/2320186>

## Technical Data

### Input data

#### DC operation

Nominal input voltage range	24 V DC
Input voltage range	18 V DC ... 28 V DC (SELV)
Input voltage range DC	18 V DC ... 28 V DC (SELV)
Voltage type of supply voltage	DC
Reverse polarity protection	< yes60 V
Nominal input current ( $I_N$ )	2x 20 A (-25 °C ... 60 °C) 1x 40 A (-25 °C ... 60 °C)
Maximum current $I_{max}$	2x 26 A (-25°C ... 40°C) 1x 52 A (-25°C ... 40°C) 120 A (12 ms, SFB Technology)
Transient surge protection	Varistor
Voltage drop, input/output	0.2 V ( $I_{OUT} = 40$ A)

### Output data

Efficiency	> 98 %
Nominal output voltage	0.2 V (< DC input)
Output voltage	$U_{IN}$ -
Nominal output current ( $I_N$ )	40 A (Increasing power) 20 A (Redundancy)
Derating	60 °C ... 70 °C (2.5%/K)
Protection against overvoltage at the output (OVP)	< 32 V DC
Power loss nominal load max.	8 W ( $I_{OUT} = 40$ A)
Connection in series	No

#### Signal: Redundancy OK, 13/14

Output description	Group contact
Maximum switching voltage	max. 30 V AC/DC
Maximum inrush current	≤ 100 mA (short-circuit-proof)

#### Signal: ACB (Auto Current Balancing) OK, 23/24

Output description	Contact closed: $\Delta U_{IN} \leq 300$ mV
Maximum switching voltage	max. 30 V AC/DC
Maximum inrush current	≤ 100 mA (short-circuit-proof)

#### Signal: Redundancy OK, 13/14

Output description	Group contact
Maximum switching voltage	max. 30 V AC/DC
Maximum inrush current	≤ 100 mA (short-circuit-proof)

# Redundancy module, with protective coating - QUINT-ORING/24DC/2X20/1X40



2320186

<https://www.phoenixcontact.com/us/products/2320186>

Signal: ACB (Auto Current Balancing) OK, 23/24

Output description	Contact closed: $\Delta U_{IN} \leq 300 \text{ mV}$
Maximum switching voltage	max. 30 V AC/DC
Maximum inrush current	$\leq 100 \text{ mA}$ (short-circuit-proof)

## Connection data

### Input

Connection method	Screw connection
Conductor cross section solid min.	0.2 mm <sup>2</sup>
Conductor cross section solid max.	6 mm <sup>2</sup>
Conductor cross section flexible min.	0.2 mm <sup>2</sup>
Conductor cross section flexible max.	4 mm <sup>2</sup>
Conductor cross section AWG min.	10
Stripping length	8 mm
Screw thread	M3
Tightening torque, min	0.5 Nm
Tightening torque max	0.6 Nm

### Output

Connection method	Screw connection
Conductor cross section solid min.	0.5 mm <sup>2</sup>
Conductor cross section solid max.	16 mm <sup>2</sup>
Conductor cross section flexible min.	0.5 mm <sup>2</sup>
Conductor cross section flexible max.	16 mm <sup>2</sup>
Conductor cross section AWG min.	6
Stripping length	10 mm
Screw thread	M4
Tightening torque, min	1.2 Nm
Tightening torque max	1.5 Nm

### Signal

Connection method	Screw connection
Conductor cross section solid min.	0.2 mm <sup>2</sup>
Conductor cross section solid max.	6 mm <sup>2</sup>
Conductor cross section flexible min.	0.2 mm <sup>2</sup>
Conductor cross section flexible max.	4 mm <sup>2</sup>
Conductor cross section AWG min.	16
Conductor cross section AWG max.	10
Stripping length	10 mm
Screw thread	M3
Tightening torque, min	0.5 Nm
Tightening torque max	0.6 Nm

# Redundancy module, with protective coating - QUINT-ORING/24DC/2X20/1X40



2320186

<https://www.phoenixcontact.com/us/products/2320186>

## LED signaling

Types of signaling	Relay contact, floating, current limited
--------------------	--

Signal output: Redundancy OK, 13/14

Status display	LED redundancy OK
Note on status display	green
Color	green

Signal output: ACB (Auto Current Balancing) OK, 23/24

Status display	ACB OK LED
Note on status display	LED bar graph green
Color	green
Note on status display	LED bar graph green

## Electrical properties

Insulation voltage input, output / housing	500 V
--	-------

## Product properties

Product type	Redundancy module
MTBF (IEC 61709, SN 29500)	> 720000 h (40 °C)

Insulation characteristics

Protection class	III
Degree of pollution	2

## Dimensions

Width	38 mm
Height	130 mm
Depth	125 mm
Horizontal pitch	2.1 Div.

Installation dimensions

Installation distance right/left	5 mm / 5 mm
Installation distance top/bottom	50 mm / 50 mm

Alternative assembly

Width	122 mm
Height	130 mm
Depth	41 mm

## Mounting

Mounting type	DIN rail mounting
---------------	-------------------

# Redundancy module, with protective coating - QUINT-ORING/24DC/2X20/1X40



2320186

<https://www.phoenixcontact.com/us/products/2320186>

Assembly instructions	alignable: $P_N \geq 50\%$ , 5 mm horizontally, 15 mm next to active components, 50 mm vertically alignable: $P_N < 50\%$ , 0 mm horizontally, 40 mm vertically top, 20 mm vertically bottom
Mounting position	horizontal DIN rail NS 35, EN 60715

## Material specifications

Inflammability class in acc. with UL 94 (housing / terminal blocks)	V0
Housing material	Metal
Type of housing	Aluminum (AlMg3)
Hood version	Galvanized sheet steel, free from chrome (VI)

## Environmental and real-life conditions

### Ambient conditions

Degree of protection	IP20
Ambient temperature (operation)	-25 °C ... 70 °C (> 60 °C Derating: 2,5 %/K)
Ambient temperature (storage/transport)	-40 °C ... 85 °C
Maximum altitude	2000 m
Climatic class	3K3 (in acc. with EN 60721)
Max. permissible relative humidity (operation)	≤ 100 % (at 25 °C, non-condensing)
Shock	18 ms, 30g, in each space direction (according to IEC 60068-2-27)
Vibration (operation)	< 15 Hz, amplitude ±2.5 mm (according to IEC 60068-2-6) 15 Hz ... 150 Hz, 2.3g, 90 min.

## Standards and regulations

Standard – Electronic equipment for use in electrical power installations and their assembly into electrical power installations	EN 50178/VDE 0160 (PELV)
Standard - Electrical safety	EN 60950-1/VDE 0805 (SELV)
Standard – Safety extra-low voltage	IEC 60950-1 (SELV) and EN 60204-1 (PELV)
Noxious gas test	ISA-S71.04-1985 G3 Harsh Group A

## Approval data

UL approvals	UL/C-UL listed UL 508
	UL/C-UL Recognized UL 60950-1
	UL ANSI/ISA-12.12.01 Class I, Division 2, Groups A, B, C, D (Hazardous Location)

### Conformity/Approvals

ATEX	□ II 3 G Ex ec nC IIC T4 Gc
	DEKRA 20ATEX0136 X
IECEX	Ex ec nC IIC T4 Gc
	DEK 20.0082X

## EMC data

# Redundancy module, with protective coating - QUINT-ORING/24DC/2X20/1X40



2320186

<https://www.phoenixcontact.com/us/products/2320186>

Low Voltage Directive	Conformance with Low Voltage Directive 2014/35/EC
Electromagnetic compatibility	Conformance with EMC Directive 2014/30/EU
EMC requirements for noise emission	EN 61000-6-3
	EN 61000-6-4
EMC requirements for noise immunity	EN 61000-6-1
	EN 61000-6-2
Noise immunity	EN 61000-6-2:2005

## Electrostatic discharge

Standards/regulations	EN 61000-4-2
-----------------------	--------------

## Electrostatic discharge

Contact discharge	8 kV (Test Level 4)
Discharge in air	15 kV (Test Level 4)
Comments	Criterion B

## Electromagnetic HF field

Standards/regulations	EN 61000-4-3
-----------------------	--------------

## Electromagnetic HF field

Frequency range	80 MHz ... 1 GHz
Test field strength	20 V/m (Test Level 3)
Frequency range	1 GHz ... 2 GHz
Test field strength	10 V/m (Test Level 3)
Frequency range	2 GHz ... 3 GHz
Test field strength	10 V/m (Test Level 3)
Comments	Criterion A

## Fast transients (burst)

Standards/regulations	EN 61000-4-4
-----------------------	--------------

## Fast transients (burst)

Input	2 kV (Test Level 3 - asymmetrical)
Output	2 kV (Test Level 3 - asymmetrical)
Signal	2 kV (Test Level 4 - asymmetrical)
Comments	Criterion B

## Surge voltage load (surge)

Standards/regulations	EN 61000-4-5
Input	1 kV (Test Level 2 - symmetrical)
	2 kV (Test Level 3 - asymmetrical)
Output	1 kV (Test Level 2 - symmetrical)
	2 kV (Test Level 3 - asymmetrical)
Signal	1 kV (Test Level 2 - asymmetrical)
Comments	Criterion B

# Redundancy module, with protective coating - QUINT-ORING/24DC/2X20/1X40



2320186

<https://www.phoenixcontact.com/us/products/2320186>

## Conducted interference

Standards/regulations	EN 61000-4-6
-----------------------	--------------

## Conducted interference

I/O/S	asymmetrical
Frequency range	0.15 MHz ... 80 MHz
Comments	Criterion A
Voltage	10 V (Test Level 3)

## Emitted interference

Standards/regulations	EN 61000-6-3
Radio interference voltage in acc. with EN 55011	EN 55011 (EN 55022) Class B, area of application: Industry and residential
Emitted radio interference in acc. with EN 55011	EN 55011 (EN 55022) Class B, area of application: Industry and residential
Criterion A	Normal operating behavior within the specified limits.
Criterion B	Temporary impairment to operational behavior that is corrected by the device itself.



# Redundancy module, with protective coating - QUINT-ORING/24DC/2X20/1X40



2320186

<https://www.phoenixcontact.com/us/products/2320186>

## Drawings

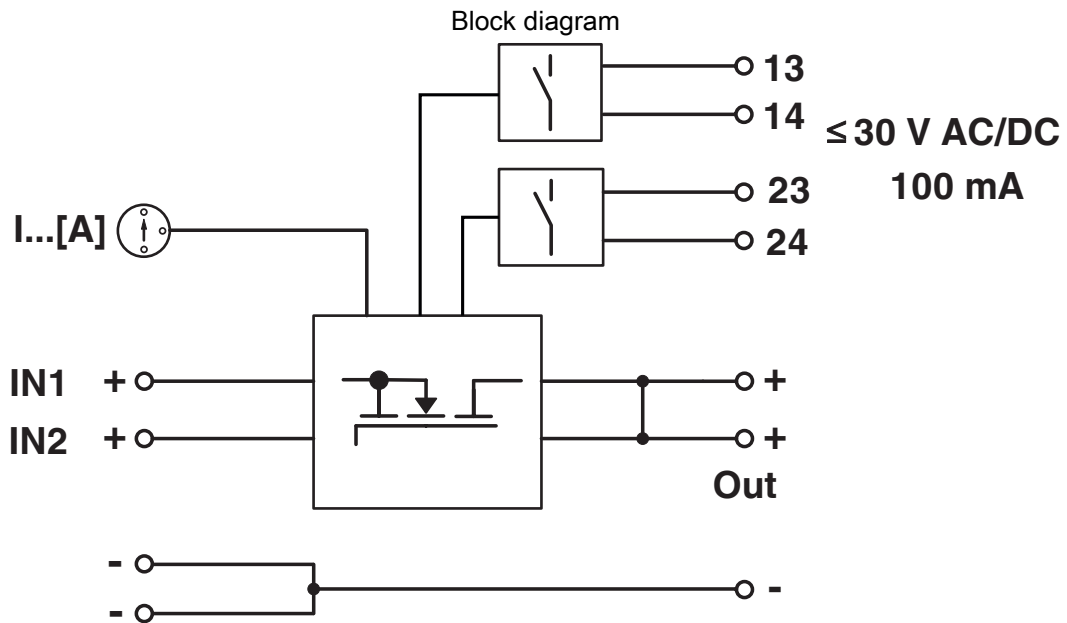

# Redundancy module, with protective coating - QUINT-ORING/24DC/2X20/1X40



2320186

<https://www.phoenixcontact.com/us/products/2320186>

## Approvals



**cUL Recognized**  
Approval ID: FILE E 211944



**UL Recognized**  
Approval ID: FILE E 211944



**EAC**  
Approval ID: EAC-Zulassung



**DNV GL**  
Approval ID: TAA000011F



**LR**  
Approval ID: 14-20005

	Nominal Voltage $U_N$	Nominal Current $I_N$	Cross Section AWG	Cross Section $\text{mm}^2$
	500 V	41 A	-	- 6



**NK**  
Approval ID: TA19447M

	Nominal Voltage $U_N$	Nominal Current $I_N$	Cross Section AWG	Cross Section $\text{mm}^2$
	500 V	63 A	-	- 10



**BV**  
Approval ID: 36077/B0 BV



**EAC**  
Approval ID: RU S-DE.BL08.W.00764



**UL Listed**  
Approval ID: FILE E 123528



**cUL Listed**  
Approval ID: FILE E 123528

# Redundancy module, with protective coating - QUINT-ORING/24DC/2X20/1X40



2320186

<https://www.phoenixcontact.com/us/products/2320186>



**RINA**

Approval ID: ELE362819XG

**ABS**

Approval ID: 20-2022537-PDA



**ATEX**

Approval ID: DEKRA 20ATEX0136 X



**EAC Ex**

Approval ID: RU C-DE.HB49.B.00004



**IECEX**

Approval ID: IECEX DEK 20.0082X



**CCC**

Approval ID: 2021322303003736



**NEPSI**

Approval ID: GYJ21.1003X



**cUL Listed**

Approval ID: FILE E 199827



**UL Listed**

Approval ID: FILE E 199827

**INMETRO**

Approval ID: DNV 19.0185 X

**cULus Recognized**

**cULus Listed**

# Redundancy module, with protective coating - QUINT-ORING/24DC/2X20/1X40



2320186

<https://www.phoenixcontact.com/us/products/2320186>

**cULus Listed**

# Redundancy module, with protective coating - QUINT-ORING/24DC/2X20/1X40



2320186

<https://www.phoenixcontact.com/us/products/2320186>

## Classifications

### ECLASS

ECLASS-9.0	27371010
ECLASS-10.0.1	27371010
ECLASS-11.0	27371010

### ETIM

ETIM 8.0	EC000683
----------	----------

### UNSPSC

UNSPSC 21.0	
-------------	--

# Redundancy module, with protective coating - QUINT-ORING/24DC/2X20/1X40



2320186

<https://www.phoenixcontact.com/us/products/2320186>

## Environmental Product Compliance

REACH SVHC	Lead 7439-92-1
China RoHS	Environmentally Friendly Use Period = 25; For information on hazardous substances, refer to the manufacturer's declaration available under "Downloads"

# Redundancy module, with protective coating - QUINT-ORING/24DC/2X20/1X40



2320186

<https://www.phoenixcontact.com/us/products/2320186>

## Accessories

### Mounting adapter

Mounting adapter - UTA 107/30 - 2320089

<https://www.phoenixcontact.com/us/products/2320089>

Universal DIN rail adapter



---

### Mounting adapter

Mounting adapter - UWA 182/52 - 2938235

<https://www.phoenixcontact.com/us/products/2938235>

Universal wall adapter for securely mounting the device in the event of strong vibrations. The device is screwed directly onto the mounting surface. The universal wall adapter is attached on the top/bottom.



# Redundancy module, with protective coating - QUINT-ORING/24DC/2X20/1X40



2320186

<https://www.phoenixcontact.com/us/products/2320186>

## Mounting adapter

Mounting adapter - QUINT-PS-ADAPTERS7/1 - 2938196

<https://www.phoenixcontact.com/us/products/2938196>

Assembly adapter for QUINT-PS... power supply on S7-300 rail



---

Phoenix Contact 2022 © - all rights reserved

<https://www.phoenixcontact.com>

Phoenix Contact USA  
586 Fulling Mill Road  
Middletown, PA 17057, United States  
(+717) 944-1300  
[info@phoenixcon.com](mailto:info@phoenixcon.com)