

Redundancy module - QUINT-ORING/24DC/2X40/1X80

2902879

<https://www.phoenixcontact.com/pc/products/2902879>

Please be informed that the data shown in this PDF document is generated from our Online Catalog. Please find the complete data in the user documentation. Our General Terms of Use for Downloads are valid.



Active QUINT redundancy module for DIN rail mounting with ACB (Auto Current Balancing) Technology and monitoring functions, input: 24 V DC/2x 40 A, output: 24 V DC/1 x 80 A, including mounted UTA 107/30 universal DIN rail adapter

Product Description

The Auto Current Balancing ACB technology of the QUINT ORING modules doubles the service life of redundantly operated power supplies by evenly utilizing the power supply units. The load current is automatically distributed symmetrically.

Your advantages

- Service life of the redundant solution is doubled, thanks to uniform distribution of the load
- Save energy
- Permanent monitoring of redundancy
- Consistent redundancy up to the load

Redundancy module - QUINT-ORING/24DC/2X40/1X80



2902879

<https://www.phoenixcontact.com/pc/products/2902879>

Commercial Data

Item number	2902879
Packing unit	1 pc
Minimum order quantity	1 pc
Product Key	CMRQ43
Catalog Page	Page 303 (C-4-2019)
GTIN	4046356698276
Weight per Piece (including packing)	1,200 g
Weight per Piece (excluding packing)	900 g
Customs tariff number	85049090
Country of origin	CN

Redundancy module - QUINT-ORING/24DC/2X40/1X80

2902879

<https://www.phoenixcontact.com/pc/products/2902879>

Technical Data

Input data

DC operation

Nominal input voltage range	24 V DC
Input voltage range	18 V DC ... 28 V DC (SELV)
Input voltage range DC	18 V DC ... 28 V DC (SELV)
Voltage type of supply voltage	DC
Reverse polarity protection	< yes60 V
Nominal input current (I_N)	2x 40 A (-25 °C ... 60 °C) 1x 80 A (-25 °C ... 60 °C)
Maximum current I_{max}	2x 45 A (-25°C ... 40°C) 1x 90 A (-25°C ... 40°C) 215 A (12 ms, SFB Technology)
Transient surge protection	Varistor
Voltage drop, input/output	0.2 V ($I_{OUT} = 80$ A)

Output data

Efficiency	> 98 %
Nominal output voltage	0.2 V (< DC input) 24 V DC
Output voltage	U_{in} -
Nominal output current (I_N)	80 A (Increasing power) 40 A (Redundancy)
Derating	60 °C ... 70 °C (2.5%/K)
Protection against overvoltage at the output (OVP)	≤ 32 V DC
Power loss nominal load max.	16 W ($I_{OUT} = 80$ A)
Connection in series	No

Signal: Redundancy OK, 13/14

Output description	Group contact
Maximum switching voltage	max. 30 V AC/DC
Maximum inrush current	≤ 100 mA (short-circuit-proof)

Signal: ACB (Auto Current Balancing) OK, 23/24

Output description	Contact closed: $\Delta U_{IN} \leq 300$ mV
Maximum switching voltage	max. 30 V AC/DC
Maximum inrush current	≤ 100 mA (short-circuit-proof)

Signal

Maximum inrush current	≤ 100 mA (short-circuit-proof)
------------------------	-------------------------------------

Signal: Redundancy OK, 13/14

Output description	Group contact
Maximum switching voltage	max. 30 V AC/DC

Redundancy module - QUINT-ORING/24DC/2X40/1X80



2902879

<https://www.phoenixcontact.com/pc/products/2902879>

Maximum inrush current	≤ 100 mA (short-circuit-proof)
------------------------	--------------------------------

Signal: ACB (Auto Current Balancing) OK, 23/24

Output description	Contact closed: $\Delta U_{IN} \leq 300 \text{ mV}$
Maximum switching voltage	max. 30 V AC/DC
Maximum inrush current	≤ 100 mA (short-circuit-proof)

Signal

Maximum inrush current	≤ 100 mA (short-circuit-proof)
------------------------	--------------------------------

Signal: Redundancy OK, 13/14

Output description	Group contact
Maximum switching voltage	max. 30 V AC/DC
Maximum inrush current	≤ 100 mA (short-circuit-proof)

Signal: ACB (Auto Current Balancing) OK, 23/24

Output description	Contact closed: $\Delta U_{IN} \leq 300 \text{ mV}$
Maximum switching voltage	max. 30 V AC/DC
Maximum inrush current	≤ 100 mA (short-circuit-proof)

Signal

Maximum inrush current	≤ 100 mA (short-circuit-proof)
------------------------	--------------------------------

Connection data

Input

Connection method	Screw connection
Conductor cross section solid min.	0.5 mm ²
Conductor cross section solid max.	16 mm ²
Conductor cross section flexible min.	0.5 mm ²
Conductor cross section flexible max.	16 mm ²
Conductor cross section AWG min.	6
Stripping length	10 mm
Screw thread	M4
Tightening torque, min	1.2 Nm
Tightening torque max	1.5 Nm

Output

Connection method	Screw connection
Conductor cross section solid min.	0.5 mm ²
Conductor cross section solid max.	35 mm ²
Conductor cross section flexible min.	0.5 mm ²
Conductor cross section flexible max.	35 mm ²
Conductor cross section AWG min.	2
Stripping length	18 mm
Screw thread	M5
Tightening torque, min	2.5 Nm

Redundancy module - QUINT-ORING/24DC/2X40/1X80



2902879

<https://www.phoenixcontact.com/pc/products/2902879>

Tightening torque max	4.5 Nm
-----------------------	--------

Signal

Connection method	Screw connection
Conductor cross section solid min.	0.2 mm ²
Conductor cross section solid max.	6 mm ²
Conductor cross section flexible min.	0.2 mm ²
Conductor cross section flexible max.	4 mm ²
Conductor cross section AWG min.	16
Conductor cross section AWG max.	10
Stripping length	10 mm
Screw thread	M3
Tightening torque, min	1.2 Nm
Tightening torque max	1.5 Nm

LED signaling

Types of signaling	Relay contact, floating, current limited
--------------------	------------------------------------------

Signal output: Redundancy OK, 13/14

Status display	LED redundancy OK
Note on status display	green

Signal output: ACB (Auto Current Balancing) OK, 23/24

Status display	ACB OK LED
Note on status display	LED bar graph green

Electrical properties

Insulation voltage input, output / housing	500 V
--------------------------------------------	-------

Product properties

Product type	Redundancy module
MTBF (IEC 61709, SN 29500)	> 720000 h (40 °C)

Insulation characteristics

Protection class	III
Degree of pollution	2

Dimensions

Width	66 mm
Height	130 mm
Depth	125 mm
Horizontal pitch	3.7 Div.

Installation dimensions

Installation distance right/left	5 mm / 5 mm
Installation distance top/bottom	50 mm / 50 mm

Redundancy module - QUINT-ORING/24DC/2X40/1X80



2902879

<https://www.phoenixcontact.com/pc/products/2902879>

Alternative assembly

Width	122 mm
Height	130 mm
Depth	69 mm

Mounting

Mounting type	DIN rail: 35 mm
Assembly instructions	alignable: $P_N \geq 50\%$, 5 mm horizontally, 15 mm next to active components, 50 mm vertically alignable: $P_N < 50\%$, 0 mm horizontally, 40 mm vertically top, 20 mm vertically bottom
Mounting position	horizontal DIN rail NS 35, EN 60715

Material specifications

Housing material	Metal
Type of housing	Aluminum (AlMg3)
Hood version	Galvanized sheet steel, free from chrome (VI)

Environmental and real-life conditions

Ambient conditions

Degree of protection	IP20
Ambient temperature (operation)	-25 °C ... 70 °C (> 60 °C Derating: 2,5 %/K)
Ambient temperature (storage/transport)	-40 °C ... 85 °C
Ambient temperature (start-up type tested)	-40 °C
Maximum altitude	2000 m 2000 m
Climatic class	3K3 (in acc. with EN 60721)
Max. permissible relative humidity (operation)	≤ 95 % (at 25 °C, non-condensing)
Shock	18 ms, 30g, in each space direction (according to IEC 60068-2-27)
Vibration (operation)	< 15 Hz, amplitude ±2.5 mm (according to IEC 60068-2-6) 15 Hz ... 150 Hz, 2.3g, 90 min.

Standards and regulations

Standard – Electronic equipment for use in electrical power installations and their assembly into electrical power installations	EN 50178/VDE 0160 (PELV)
Standard - Electrical safety	EN 60950-1/VDE 0805 (SELV)
Standard – Safety extra-low voltage	IEC 60950-1 (SELV) and EN 60204-1 (PELV)

Approval data

UL approvals	UL/C-UL listed UL 508
	UL/C-UL Recognized UL 60950-1
	UL ANSI/ISA-12.12.01 Class I, Division 2, Groups A, B, C, D (Hazardous Location)

Conformity/Approvals

Redundancy module - QUINT-ORING/24DC/2X40/1X80



2902879

<https://www.phoenixcontact.com/pc/products/2902879>

SIL in accordance with IEC 61508	0
----------------------------------	---

EMC data

Low Voltage Directive	Conformance with Low Voltage Directive 2014/35/EC
Electromagnetic compatibility	Conformance with EMC Directive 2014/30/EU
EMC requirements for noise emission	EN 61000-6-3
	EN 61000-6-4
EMC requirements for noise immunity	EN 61000-6-1
	EN 61000-6-2
Noise immunity	EN 61000-6-2:2005

Electrostatic discharge

Standards/regulations	EN 61000-4-2
-----------------------	--------------

Electrostatic discharge

Contact discharge	8 kV (Test Level 4)
Discharge in air	15 kV (Test Level 4)
Comments	Criterion B

Electromagnetic HF field

Standards/regulations	EN 61000-4-3
-----------------------	--------------

Electromagnetic HF field

Frequency range	80 MHz ... 1 GHz
Test field strength	20 V/m (Test Level 3)
Frequency range	1 GHz ... 2 GHz
Test field strength	10 V/m (Test Level 3)
Frequency range	2 GHz ... 3 GHz
Test field strength	10 V/m (Test Level 3)
Comments	Criterion A

Fast transients (burst)

Standards/regulations	EN 61000-4-4
-----------------------	--------------

Fast transients (burst)

Input	2 kV (Test Level 3 - asymmetrical)
Output	2 kV (Test Level 3 - asymmetrical)
Signal	2 kV (Test Level 4 - asymmetrical)
Comments	Criterion B

Surge voltage load (surge)

Standards/regulations	EN 61000-4-5
Input	1 kV (Test Level 2 - symmetrical)
	2 kV (Test Level 3 - asymmetrical)
Output	1 kV (Test Level 2 - symmetrical)
	2 kV (Test Level 3 - asymmetrical)
Signal	1 kV (Test Level 2 - asymmetrical)

Redundancy module - QUINT-ORING/24DC/2X40/1X80



2902879

<https://www.phoenixcontact.com/pc/products/2902879>

Comments	Criterion B
Conducted interference	
Standards/regulations	EN 61000-4-6
Conducted interference	
I/O/S	asymmetrical
Frequency range	0.15 MHz ... 80 MHz
Comments	Criterion A
Voltage	10 V (Test Level 3)
Emitted interference	
Standards/regulations	EN 61000-6-3
Radio interference voltage in acc. with EN 55011	EN 55011 (EN 55022) Class B, area of application: Industry and residential
Emitted radio interference in acc. with EN 55011	EN 55011 (EN 55022) Class B, area of application: Industry and residential
Criterion A	Normal operating behavior within the specified limits.
Criterion B	Temporary impairment to operational behavior that is corrected by the device itself.

Redundancy module - QUINT-ORING/24DC/2X40/1X80

2902879

<https://www.phoenixcontact.com/pc/products/2902879>

Drawings

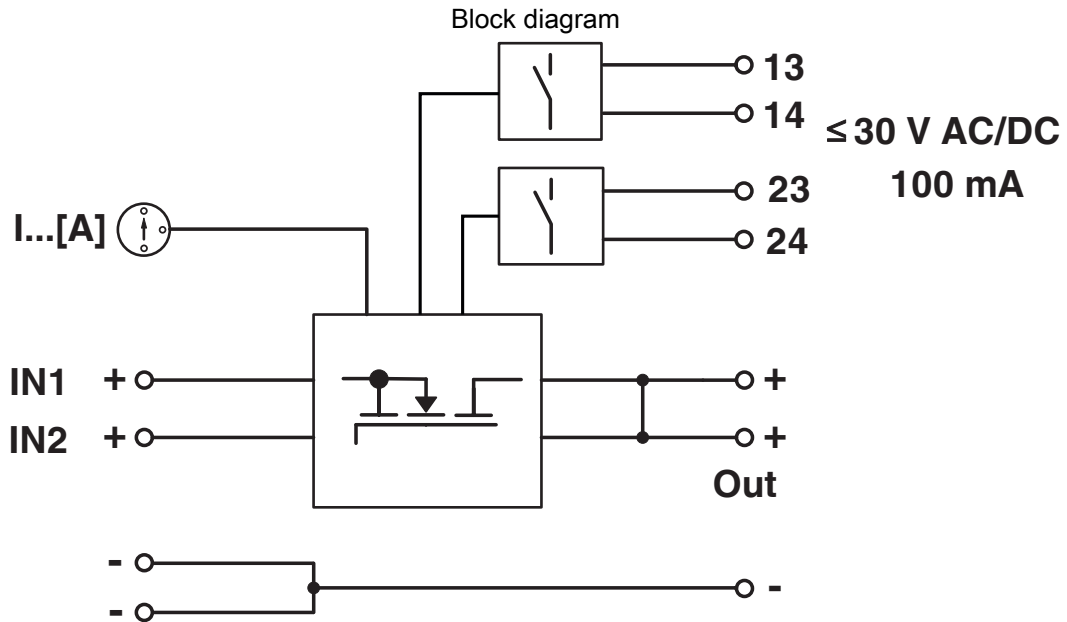

Redundancy module - QUINT-ORING/24DC/2X40/1X80



2902879

<https://www.phoenixcontact.com/pc/products/2902879>

Approvals



UL Recognized

Approval ID: FILE E 211944



cUL Recognized

Approval ID: FILE E 211944



cUL Listed

Approval ID: FILE E 123528



UL Listed

Approval ID: FILE E 123528

ABS

Approval ID: 20-2022537-PDA



BV

Approval ID: 36077/B0 BV



DNV GL

Approval ID: TAA000011F

ClassNK

NK

Approval ID: TA19447M



RINA

Approval ID: ELE362819XG



LR

Approval ID: 14-20005



EAC

Approval ID: RU S-DE.BL08.W.00764



EAC

Approval ID: RU S-DE.BL08.W.00764

Redundancy module - QUINT-ORING/24DC/2X40/1X80



2902879

<https://www.phoenixcontact.com/pc/products/2902879>



cUL Recognized
Approval ID: FILE E 211944



UL Recognized
Approval ID: FILE E 211944



EAC
Approval ID: EAC-Zulassung



DNV GL
Approval ID: TAA000011F



LR
Approval ID: 14-20005



NK
Approval ID: TA19447M



BV
Approval ID: 36077/B0 BV



EAC
Approval ID: EAC-Zulassung



UL Listed
Approval ID: FILE E 123528



cUL Listed
Approval ID: FILE E 123528



RINA
Approval ID: ELE362819XG



ABS
Approval ID: 20-2022537-PDA

Redundancy module - QUINT-ORING/24DC/2X40/1X80



2902879

<https://www.phoenixcontact.com/pc/products/2902879>



UL Listed

Approval ID: FILE E 199827



cUL Listed

Approval ID: FILE E 199827



cUL Listed

Approval ID: FILE E 199827



UL Listed

Approval ID: FILE E 199827

Redundancy module - QUINT-ORING/24DC/2X40/1X80



2902879

<https://www.phoenixcontact.com/pc/products/2902879>

Classifications

ECLASS

ECLASS-9.0	27371010
ECLASS-10.0.1	27371010
ECLASS-11.0	27371010

ETIM

ETIM 8.0	EC000683
----------	----------

UNSPSC

UNSPSC 21.0	
-------------	--

Redundancy module - QUINT-ORING/24DC/2X40/1X80



2902879

<https://www.phoenixcontact.com/pc/products/2902879>

Environmental Product Compliance

REACH SVHC	Lead 7439-92-1
China RoHS	Environmentally Friendly Use Period = 25;
	For information on hazardous substances, refer to the manufacturer's declaration available under "Downloads"

Redundancy module - QUINT-ORING/24DC/2X40/1X80

2902879

<https://www.phoenixcontact.com/pc/products/2902879>

Accessories

DIN rail adapter

DIN rail adapter - UTA 107 - 2853983

<https://www.phoenixcontact.com/pc/products/2853983>

Universal DIN rail adapter, for screwing on switchgear



Mounting adapter

Mounting adapter - UWA 182/52 - 2938235

<https://www.phoenixcontact.com/pc/products/2938235>

Universal wall adapter for securely mounting the device in the event of strong vibrations. The device is screwed directly onto the mounting surface. The universal wall adapter is attached on the top/bottom.



Redundancy module - QUINT-ORING/24DC/2X40/1X80

2902879

<https://www.phoenixcontact.com/pc/products/2902879>

Mounting adapter

Mounting adapter - QUINT-PS-ADAPTERS7/1 - 2938196

<https://www.phoenixcontact.com/pc/products/2938196>

Assembly adapter for QUINT-PS... power supply on S7-300 rail



Phoenix Contact 2022 © - all rights reserved
<https://www.phoenixcontact.com>

PHOENIX CONTACT GmbH & Co. KG
Flachmarktstraße 8
D-32825 Blomberg
+49 (0) 5235-3 00
info@phoenixcontact.com