

SD-D/SC/LA - Socket

2964898

<https://www.phoenixcontact.com/nz/products/2964898>



Please be informed that the data shown in this PDF document is generated from our online catalog. Please find the complete data in the user documentation. Our general terms of use for downloads are valid.



Control cabinet socket, for mounting on DIN rails and in the service interface, with screw connection, with light indicator, housing color: green, national version: D

Commercial data

Item number	2964898
Packing unit	5 pc
Minimum order quantity	5 pc
Sales key	BG4611
Product key	BE7611
Catalog page	Page 540 (C-5-2015)
GTIN	4017918190651
Weight per piece (including packing)	78.106 g
Weight per piece (excluding packing)	78.106 g
Country of origin	GR

Technical data

Product properties

Product type	Socket
For country-specific use in	D

Electrical properties

Nominal voltage U_N	250 V AC
Nominal current I_N	16 A

Signaling

Status display	Glow lamp or LED with preresistor
----------------	-----------------------------------

Dimensions

Width	45 mm
Height	75 mm
Depth	65.2 mm

Material specifications

Color	green
Insulating material	PA
Contact material	CuZn37

Environmental and real-life conditions

Ambient conditions

Degree of protection	IP20
Ambient temperature (operation)	-20 °C ... 60 °C
Ambient temperature (storage/transport)	-20 °C ... 60 °C

Standards and regulations

Standards

Standards/regulations	IEC 83
	DIN 49440-1

Mounting

Connection method	Screw connection
-------------------	------------------

SD-D/SC/LA - Socket

2964898

<https://www.phoenixcontact.com/nz/products/2964898>



Drawings

Circuit diagram

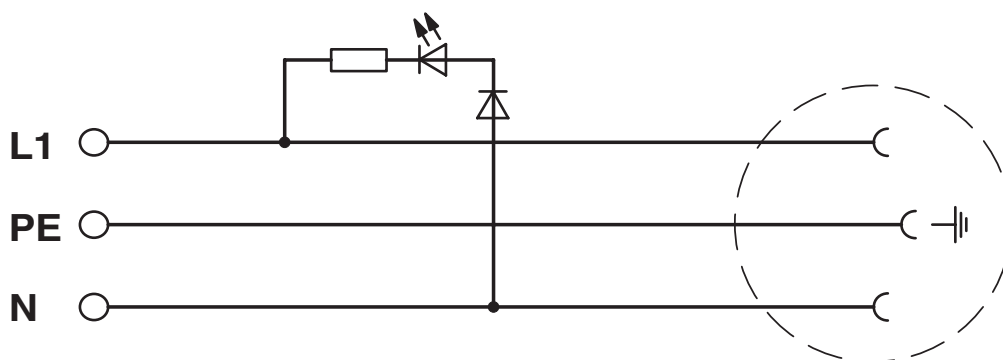

SD-D/SC/LA - Socket



2964898

<https://www.phoenixcontact.com/nz/products/2964898>

Environmental product compliance

REACH SVHC	Lead 7439-92-1
	Hexahydromethylphthalic anhydride
China RoHS	Environmentally Friendly Use Period = 50 years
	For information on hazardous substances, refer to the manufacturer's declaration available under "Downloads"

Phoenix Contact 2023 © - all rights reserved
<https://www.phoenixcontact.com>

PHOENIX CONTACT Ltd
Unit 15C, 906-930 Great South Road, Penrose
Auckland 1061
0508 474 636
sales@phoenixcontact.co.nz